

J-mini • J-INOX • MG-INOX • JBR

Elettropompe autoadescanti / Self-priming electric pumps



J-mini

Corrente continua / Direct current



J-INOX



MG-INOX

(N° 04 giranti / impellers)



JBR



JBR 3

Corrente continua / Direct current

DESCRIZIONE E APPLICAZIONI

Elettropompe centrifughe **autoadescanti** tipo Jet a girante chiusa, dalla elevata capacità di aspirazione, comunemente utilizzate per la distribuzione di acqua in pressione nei servizi di bordo (docce, cucine, lavandini, wc, ecc.), per gruppi di condizionamento, antincendio, lavaggio ponti e catene.

Tale esercizio avviene automaticamente con l'ausilio di piccoli o medi serbatoi autoclave. Le elettropompe serie **J-mini**, **J-INOX** e **MG-INOX** sono indicate per l'utilizzo con acqua dolce, le elettropompe serie **JBR** sono idonee all'utilizzo con acqua dolce e acqua di mare.

DESCRIPTION AND USE

Self-priming centrifugal electric pumps Jet type with closed impeller, featuring a high suction capacity, widely used to deliver pressurized water to on-board appliances (such as showers, kitchens, washbasins, toilets, etc.), for air-conditioning units, fire-fighting, washing of decks and chains.

Automatic operation is achieved by equipping the pumps with small or medium-sized surge tanks.

The pumps series **J-mini**, **J-INOX** e **MG-INOX** are suitable for fresh water, the pumps series **JBR** are suitable for both fresh and sea water.

CARATTERISTICHE COSTRUTTIVE

- **Serie J-mini / J-INOX / MG-INOX**
Corpo pompa: ACCIAIO INOX AISI 304.
Albero : ACCIAIO INOX AISI 316 (c.c.) - AISI 420 (c.a.).
Diffusore e tubo Venturi: NORYL (Technopolimero).
Girante/i: NORYL (Technopolimero).
Tenuta meccanica: CERAMICA - GRAFITE-NBR (speciale anti-corrosione).
- **Serie JBR**
Corpo pompa: BRONZO
Supporto motore: BRONZO
Albero : ACCIAIO INOX AISI 316
Diffusore e tubo Venturi: POLICARBONATO.
Girante: LEGA SPECIALE DI OTTONE
Tenuta meccanica: CERAMICA - GRAFITE-NBR (speciale anti-corrosione)

CONSTRUCTION FEATURES

- **J-mini / J-INOX / MG-INOX Series**
Pump body: AISI 304 STAINLESS STEEL
Shaft : AISI 316 (d.c.) - AISI 420 (a.c.) STAINLESS STEEL
Diffuser and Venturi tube: NORYL (Technopolymer)
Impeller/s: NORYL (Technopolymer).
Mechanical seal: CERAMICS - GRAPHITE - NBR (special corrosion-proof).
- **JBR series**
Pump body: BRONZE
Motor support: BRONZE
Shaft : AISI 316 STAINLESS STEEL
Diffuser and Venturi Tube: POLYCARBONATE
Impeller: SPECIAL BRASS ALLOY
Mechanical seal: CERAMICS - GRAPHITE - NBR (special corrosion-proof).

MOTORE

- **Corrente Continua:**
Motore elettrico a bobine di campo e magneti permanenti 12/24V, protezione IP23, Classe di Isolamento F, Servizio continuo (S1).
- **Corrente Alternata:**
Motore elettrico asincrono 230V monofase (M) / 230-400V trifase (T), 50Hz, protezione IP44-54, Classe di Isolamento F, Servizio continuo (S1).

MOTOR

- **Direct Current:**
Wound field and permanent magnet electric motor 12/24V, Protection IP23, Insulation Class F, Continuous Duty (S1).
- **Alternate Current:**
Induction electric motor, 230V single-phase (M) / 230-400V three-phase (T), 50Hz, Protection IP44-54, Insulation Class F, Continuous Duty (S1).

LIMITI DI IMPIEGO

- Liquido esente da impurità solide
- Temperatura del liquido: da +0 a +50 ° (70°C per la serie JBR).
- Profondità max. di aspirazione: 9 m.
- Pressione statica nel corpo pompa: 6 bar max.

SCOPE

- Liquid free of solid impurities
- Temperature range of the liquid: from +0 to +50 °C (70°C for JBR series)
- Max. suction depth: 9 m.
- Static pressure inside the pump body: 6 bar max.

ACCESSORI A RICHIESTA

- Valvola di non ritorno da 1" o da 1" 1/2
- "Base omega" in acciaio inox con antivibranti

ACCESSORIES ON REQUEST

- Non-return valve 1" or 1" 1/2
- "Omega base" made in stainless steel with antivibrations

J-mini • J-INOX • MG-INOX • JBR

Elettropompe autoadesanti / Self-priming electric pumps

PRESTAZIONI / PERFORMANCES

Modello Type	Materiale Material	Vtaggio Voltage (V)	Potenza Power		Assorbimento Absorption (A)	Giri/min. RPM	Portata Max. Max. delivery (l/min.)	Prevalenza Max. Max. head (m)
			HP	kW				
J-mini	Acciaio inox Stainless steel	12	0,4	0,3	33	2200	55	28
		24	0,5	0,4	20	2600	55	30
		230M	0,75	0,55	3,8	2800	55	39
		230+400T	0,75	0,55	3,6+1,9	2800	55	39
J-INOX	Acciaio inox Stainless steel	12	0,7	0,52	40	2400	50	30
		24	0,8	0,6	28	2650	50	38
		230M	0,9	0,7	4	2800	58	45
		230+400T	0,9	0,7	3,8+2	2800	58	45
MG-INOX	Acciaio inox Stainless steel	24	1	0,75	40	2800	90	50
		230M	1	0,75	5	2800	90	50
		230+400T	1	0,75	4,8+2,6	2800	90	50

Modello Type	Materiale Material	Vtaggio Voltage (V)	Potenza Power		Assorbimento Absorption (A)	Giri/min. RPM	Portata Max. Max. delivery (l/min.)	Prevalenza Max. Max. head (m)
			HP	kW				
JBR	Bronzo Bronze	12	0,7	0,52	42	2200	44	30
		24	0,8	0,6	28	2600	55	36
		230M	0,8	0,6	4,5	2800	55	52
		230+400T	0,8	0,6	3+1,7	2800	55	52
JBR 2	Bronzo Bronze	24	1	0,75	45	2800	75	40
		230M	1	0,75	5,7	2800	75	42
		230+400T	1	0,75	3,7+2,2	2800	75	42
JBR 3	Bronzo Bronze	24V	1,5	1,1	60	2800	100	50
		230M	1,5	1,1	7,4	2800	100	50
		230+400T	1,5	1,1	5+2,9	2800	100	50
JBR 4	Bronzo Bronze	230M	2	1,5	9,2	2800	160	50
		230+400T	2	1,5	7,5+2,3	2800	160	52
JBR 5	Bronzo Bronze	230+400T	3	2,2	9,1+5,3	2800	160	60

12V-24V: CORRENTE CONTINUA / DIRECT CURRENT

230M, 50Hz: corrente alternata monofase / single-phase alternate current

230+400T, 50Hz: corrente alternata trifase / three-phase alternate current

A richiesta disponibili altri voltaggi a 50Hz e 60Hz / Available on request other voltages at 50Hz and 60Hz.

J-mini • J-INOX • MG-INOX • JBR

Elettropompe autoadescanti / Self-priming electric pumps

CORRENTE CONTINUA (c.c.) / DIRECT CURRENT (d.c.)

DIMENSIONI E PESI / DIMENSIONS AND WEIGHTS

J-mini

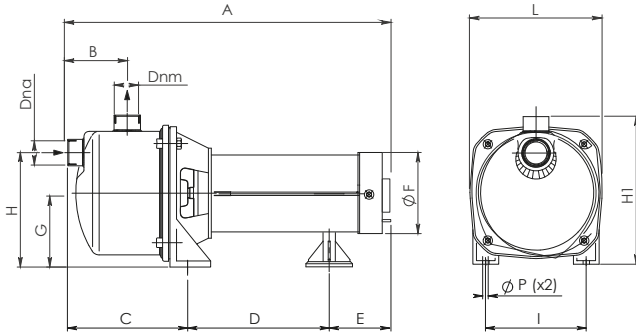

J-INOX / MG-INOX

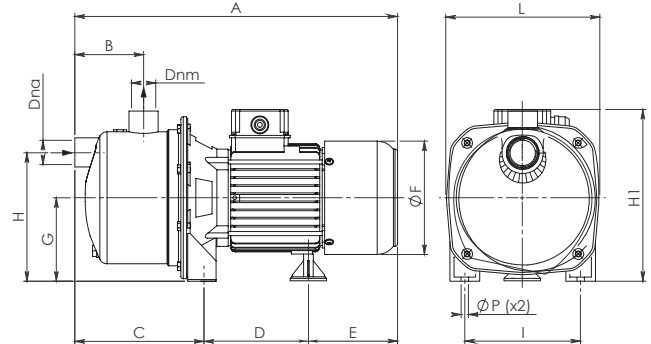

Modello Type	Corrente Current	Dna (Gas - BSP)	Dnm (Gas - BSP)	A	B	C	D	E	ØF	G	H	H1	I	L	ØP	Peso Weight (kg)
J-mini	c.c - d.c.	1"	1"	385	71	160	175	50	80	80	125	180	125	160	10	5
J-INOX	c.c - d.c.	1"	1"	400	80	160	130	110	139	95	150	215	140	185	10	10
MG-INOX	c.c - d.c.	1"	1"	507	128	205	162	140	156	95	150	230	140	200	10	15

Misure in millimetri (mm), dimensioni non impegnative / Measures in millimeter (mm), dimensions approximated

JBR / JBR2

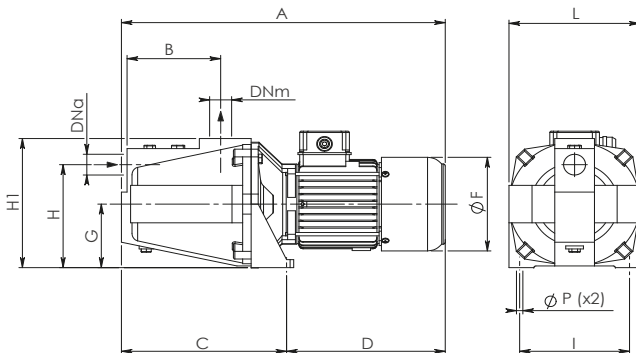

JBR3

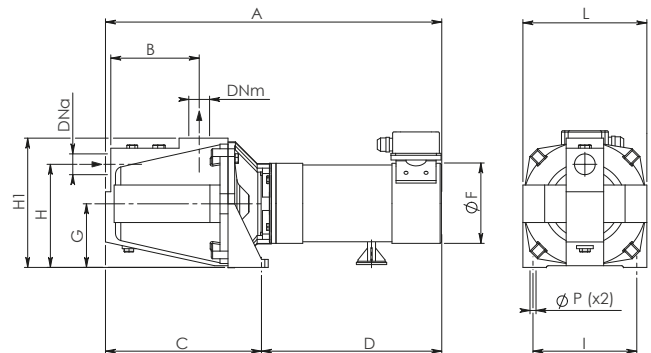

Modello Type	Corrente Current	Dna (Gas - BSP)	Dnm (Gas - BSP)	A	B	C	D	ØF	G	H	H1	I	L	ØP	Peso Weight (kg)
JBR	c.c - d.c.	1"	1"	455	130	233	222	139	95	150	195	155	185	9,5	25
JBR 2	c.c - d.c.	1"	1"	455	130	233	222	139	95	150	195	155	185	9,5	25,7
JBR 3	c.c - d.c.	1 1/2"	1"	630	165	290	340	116	110	165	222	175	215	13	30

Misure in millimetri (mm), dimensioni non impegnative / Measures in millimeter (mm), dimensions approximated

J-mini • J-INOX • MG-INOX • JBR

Elettropompe autoadescanti / Self-priming electric pumps

CORRENTE ALTERNATA (c.a.) / ALTERNATE CURRENT (a.c.)

PRESTAZIONI / PERFORMANCES

J-mini / J-INOX / MG-INOX

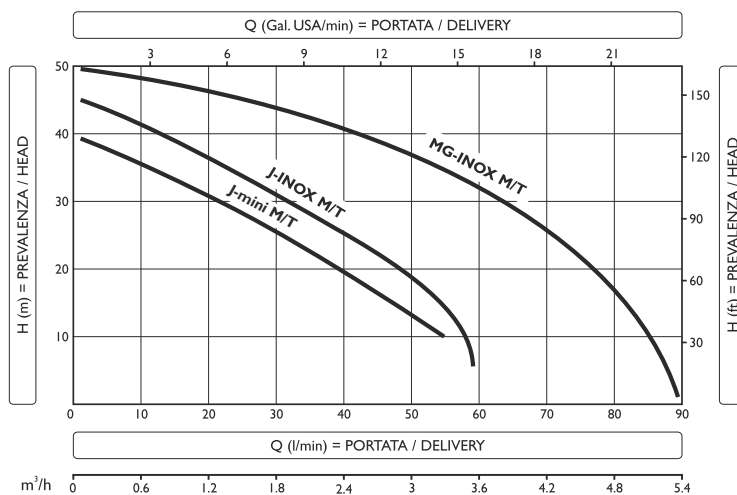

Modello Type	Voltaggio Voltage (V)	Potenza / Power		Assorbimento Absorption (A)	Giri/min. RPM	Q	H (m)												
		HP	kW				m ³ /h	0	0,6	1,2	1,5	1,8	2,4	2,9	3,3	3,5	3,9	4,5	5,1
J-mini	230M	0,75	0,55	3,8	2800	H (m)	0	0,6	1,2	1,5	1,8	2,4	2,9	3,3	3,5	3,9	4,5	5,1	5,4
	230+400T	0,75	0,55	3,6+1,9	2800		0	0,6	1,2	1,5	1,8	2,4	2,9	3,3	3,5	3,9	4,5	5,1	5,4
J-INOX	230M	0,9	0,7	4	2800		0	0,6	1,2	1,5	1,8	2,4	2,9	3,3	3,5	3,9	4,5	5,1	5,4
	230+400T	0,9	0,7	3,8+2	2800		0	0,6	1,2	1,5	1,8	2,4	2,9	3,3	3,5	3,9	4,5	5,1	5,4
MG-INOX	230M	1	0,75	5	2800		0	0,6	1,2	1,5	1,8	2,4	2,9	3,3	3,5	3,9	4,5	5,1	5,4
	230+400T	1	0,75	4,8+2,6	2800		0	0,6	1,2	1,5	1,8	2,4	2,9	3,3	3,5	3,9	4,5	5,1	5,4

JBR

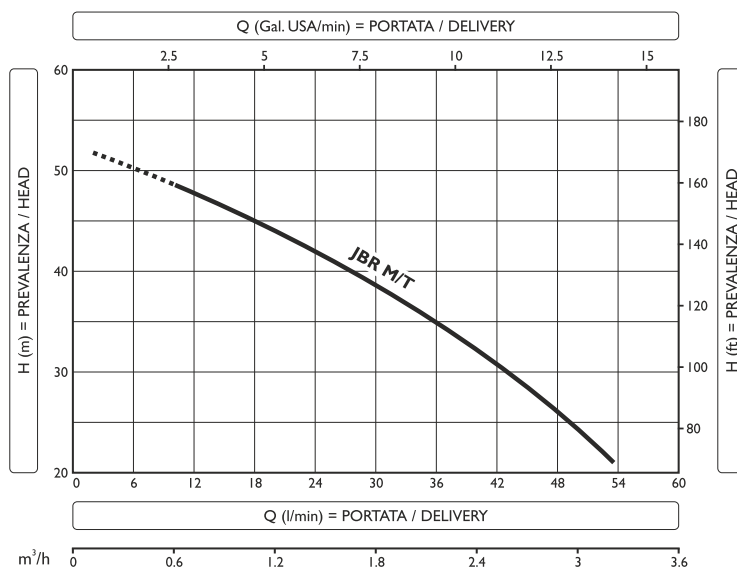

Modello Type	Voltaggio Voltage (V)	Potenza / Power		Assorbimento Absorption (A)	Giri/min. RPM	Q	H (m)								
		HP	kW				m ³ /h	0,2	0,5	1	1,5	2	2,5	3	3,2
JBR	230M	0,75	0,55	4,5	2800	H (m)	0	0,2	0,5	1	1,5	2	2,5	3	3,2
	230+400T	0,75	0,55	3+1,7	2800		0	0,2	0,5	1	1,5	2	2,5	3	3,2

CORRENTE ALTERNATA (c.a.) / ALTERNATE CURRENT (a.c.)

PRESTAZIONI / PERFORMANCES

JBR 4

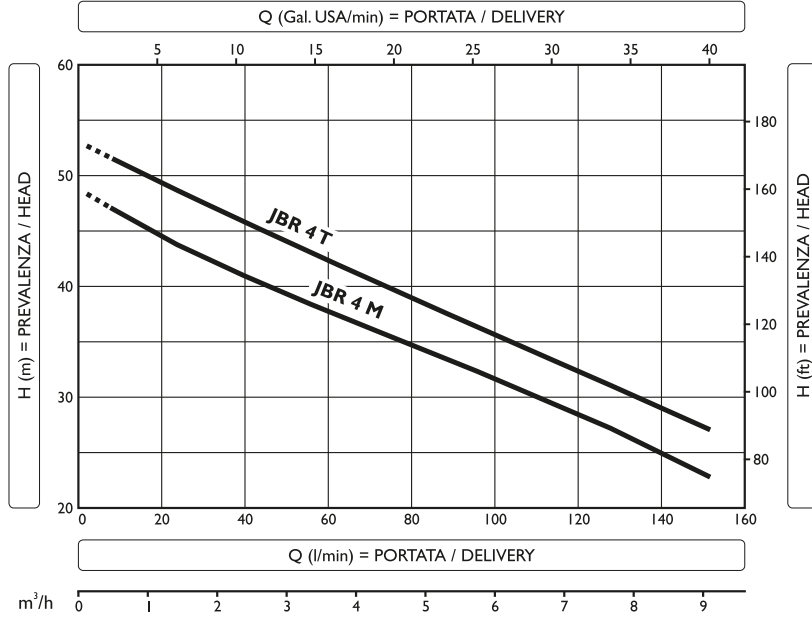

JBR 5

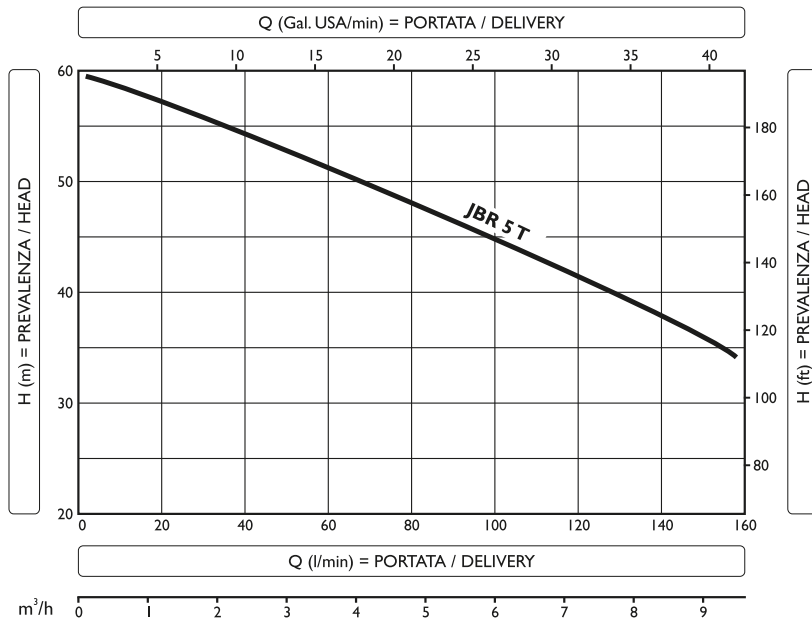

Modello Type	Voltaggio Voltage (V)	Potenza / Power		Assorbimento Absorption (A)	Giri/min. RPM	Q	Flow Rate (Q)																			
		HP	kW				m ³ /h	l/min	0,5	1	1,5	2	2,5	3	3,5	4	4,5	5	5,5	6	6,5	7	8	9	9,5	
JBR 4	230M	2	1,5	9,2	2800	H (m)	47	45	44	42	41	40	38	37	36	35	33	32	31	30	27	24	23			
	230+400T	2	1,5	7,5+4,3	2800		52	50	49	47	46	45	43	42	40	39	38	37	35	34	31	29	27			
JBR 5	230+400T	3	2,2	9,2+5,3	2800		59	58	57	55	54	53	51	50	49	47	46	44	43	42	38	35	34			

J-mini • J-INOX • MG-INOX • JBR

Elettropompe autoadescanti / Self-priming electric pumps

CORRENTE ALTERNATA (c.a.) / ALTERNATE CURRENT (a.c.)

DIMENSIONI E PESI / DIMENSIONS AND WEIGHTS

J-mini

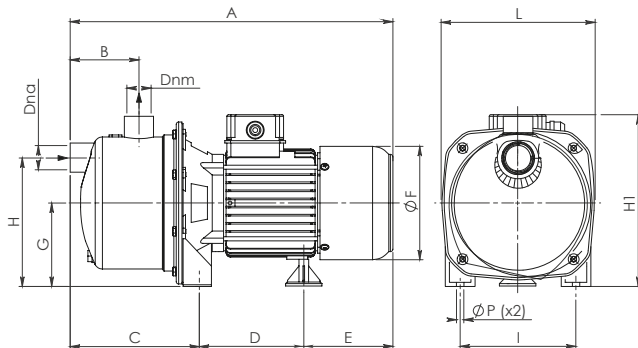

J-INOX / MG-INOX

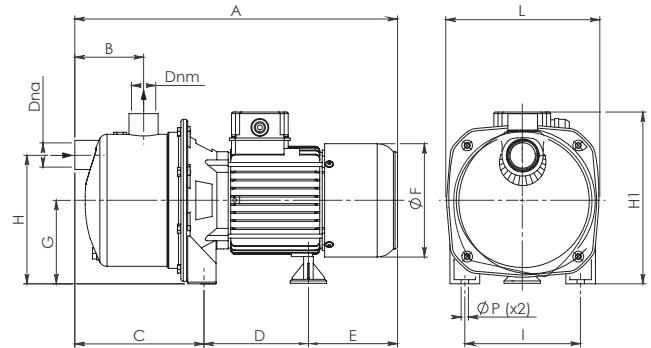

Modello Type	Corrente Current	Dna (Gas - BSP)	Dnm (Gas - BSP)	A	B	C	D	E	ØF	G	H	H1	I	L	ØP	Peso Weight (kg)
J-mini	c.a - a.c	1"	1"	320	72	163	107	50	115	90	125	180	126	160	9	7
J-INOX	c.a - a.c	1"	1"	345	80	160	110	75	123	95	150	200	140	185	10	8,5
MG-INOX	c.a - a.c	1"	1"	420	128	205	125	90	139	95	150	215	140	200	10	11,5

Misure in millimetri (mm), dimensioni non impegnative / Measures in millimeter (mm), dimensions approximated

JBR

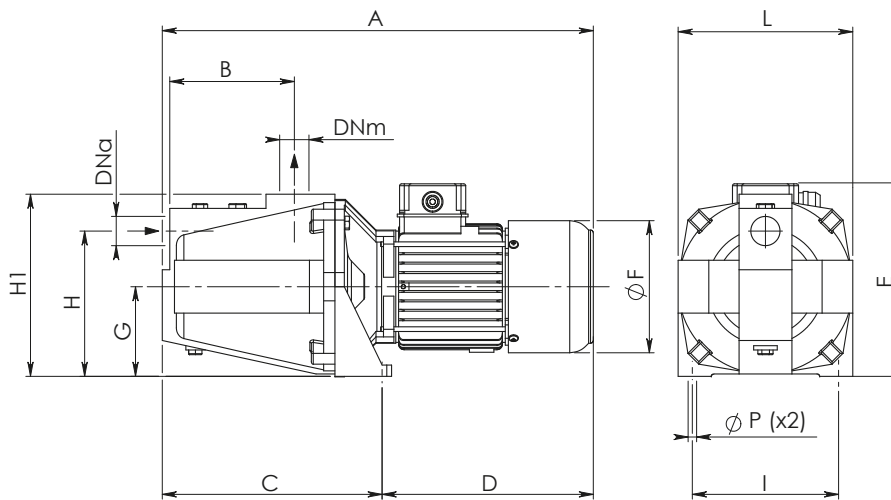

Modello Type	Corrente Current	Dna (Gas - BSP)	Dnm (Gas - BSP)	A	B	C	D	E	ØF	G	H	H1	I	L	ØP	Peso Weight (kg)
JBR	c.a - a.c	1"	1"	430	130	233	197	205	139	95	150	195	155	185	9,5	21
JBR 2	c.a - a.c	1"	1"	430	130	233	197	205	139	95	150	195	155	185	9,5	21,7
JBR 3	c.a - a.c	1"1/2	1"	560	160	290	270	230	158	105	165	222	175	215	11,5	31,5
JBR 4	c.a - a.c	1"1/2	1"	560	160	290	270	230	158	105	165	222	175	215	11,5	33
JBR 5	c.a - a.c	1"1/2	1"	560	160	290	270	230	158	105	165	222	175	215	11,5	33,5

Misure in millimetri (mm), dimensioni non impegnative / Measures in millimeter (mm), dimensions approximated